

# SETUP SHEET

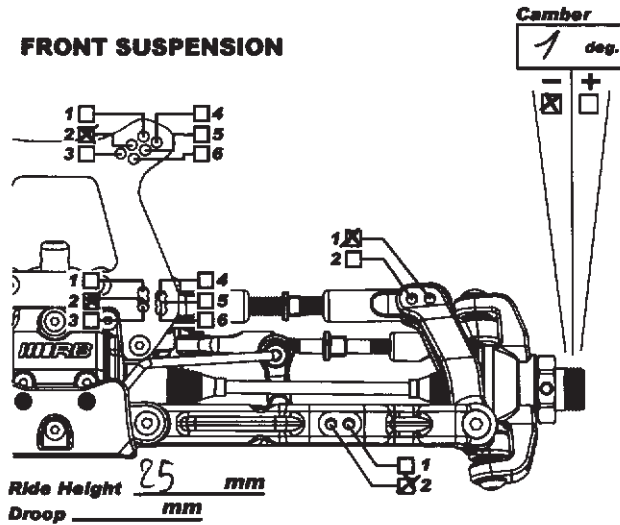

Name:	Champion CFB
Track:	Limoge
Date:	25/03/11
Temperature:	15°C
Engine:	RB B11
Plug:	6
Venturi:	7 mm
Fuel:	RB 25%
Muffler:	198 + 2087
Clutch bell:	15 T
Spur gear:	46 T
Clutch Material	alloy composite <input type="checkbox"/> <input checked="" type="checkbox"/>
Diff Center:	7000 OIL
Diff Front:	5000 OIL
Diff Rear:	2000 OIL

## FRONT SUSPENSION



## FRONT SHOCK

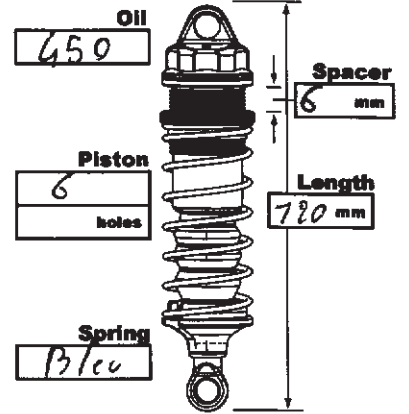

## REAR SUSPENSION

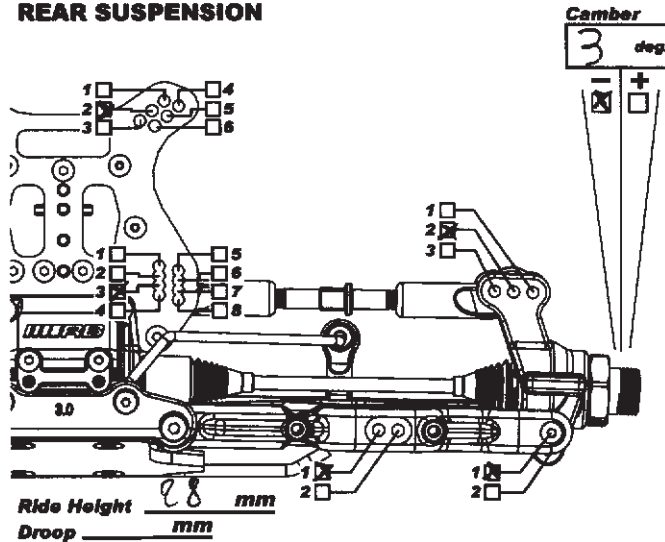

## REAR SHOCK

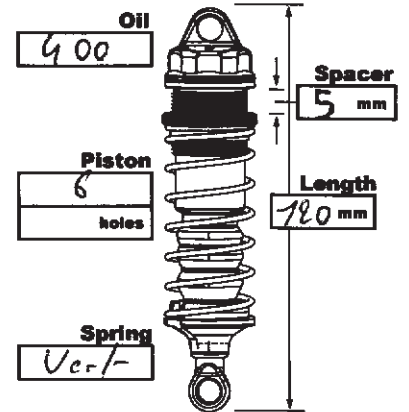

## FRONT TOE ANGLE

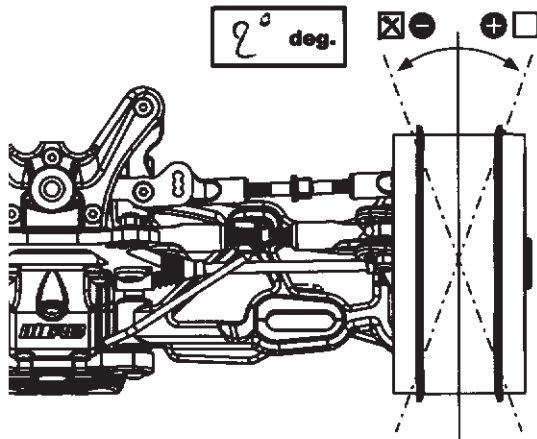

## FRONT

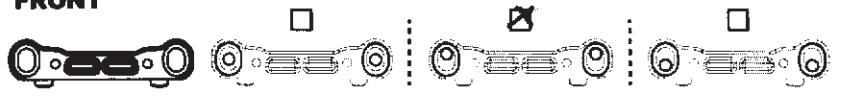

## REAR

